

SAMSUNG

User guide

HG43U700F* HG50U700F* HG55U700F*
HG65U700F* HG75U700F*
HG43U800F* HG50U800F* HG55U800F*
HG65U800F* HG75U800F* HG85U800F*

Thank you for purchasing this Samsung product.

To receive more complete service, please register your product at www.samsung.com

Model _____ Serial No. _____

Before Reading This User guide

This TV B2B (Business to Business) model is designed for hotels or the other hospitality businesses, supports a variety of special functions, and lets you limit some user (guest) controls.

Figures and illustrations in this User guide are provided for reference only and may differ from the actual product appearance. Product design and specifications may change without notice.

Operational Modes

This TV has two modes: **Interactive** and **Standalone** mode.

- **Interactive** mode: In this mode, the TV communicates with and is fully or partially controlled by a connected Set Back Box (SBB) or Set Top Box (STB) provided by a hospitality System Integration (SI) vendor. When the TV is initially plugged in, it sends a command that attempts to identify the SBB or STB connected to it. If the TV identifies the SBB or STB and the SBB or STB identifies the TV, the TV gives full control to the SBB or STB.
- **Standalone** mode: In this mode, the TV works alone without an external SBB or the STB.

The TV has a **Hotel Option** menu that lets you easily set its various hospitality functions. Please see page 16.

The menu also lets you activate or de-activate some TV and hospitality functions so you can create your optimal hospitality configuration.

Still image warning







Avoid displaying still images (such as jpeg picture files) or still image elements (such as TV channel logos, panorama or 4:3 format images, stock or news bars or crawls) on the screen. Displaying still pictures continually can cause uneven screen wear, which will affect image quality. To reduce the chance that this effect will occur, please follow the recommendations below:

- Avoid displaying the same TV channel for long periods.
- Always try to display a full screen image.
- Reduce brightness and contrast to help prevent the occurrence of after-images.
- Use all TV features designed to reduce image retention and screen burn-in.

Warning! Important Safety Instructions

Please read the Safety Instructions before using your TV.

Refer to the table below for an explanation of symbols which may be on your Samsung product.

CAUTION	
RISK OF ELECTRIC SHOCK. DO NOT OPEN.	
CAUTION: TO REDUCE THE RISK OF ELECTRIC SHOCK, DO NOT REMOVE COVER (OR BACK). THERE ARE NO USER SERVICEABLE PARTS INSIDE. REFER ALL SERVICING TO QUALIFIED PERSONNEL.	
	This symbol indicates that high voltage is present inside. It is dangerous to make any kind of contact with any internal part of this product.
	This symbol indicates that this product has included important literature concerning operation and maintenance.
	Class II product: This symbol indicates that a safety connection to electrical earth (ground) is not required. If this symbol is not present on a product with a power cord, the product MUST have a reliable connection to protective earth (ground).
	AC voltage: Rated voltage marked with this symbol is AC voltage.
	DC voltage: Rated voltage marked with this symbol is DC voltage.
	Caution. Consult instructions for use: This symbol instructs the user to consult the User guide for further safety related information.

- The slots and openings in the cabinet and in the back or bottom are provided for necessary ventilation. To ensure reliable operation of this apparatus and to protect it from overheating, these slots and openings must never be blocked or covered.
 - Do not place this apparatus in a confined space, such as a bookcase or built-in cabinet, unless proper ventilation is provided.
 - Do not place this apparatus near or over a radiator or heat register, or where it is exposed to direct sunlight.
 - Do not place vessels (vases etc.) containing water on this apparatus, as this can result in a fire or electric shock.
- Do not expose this apparatus to rain or place it near water (near a bathtub, washbowl, kitchen sink, or laundry tub, in a wet basement, or near a swimming pool, etc.). If this apparatus accidentally gets wet, unplug it and contact an authorised dealer immediately.

- Please contact your local authorities for disposal or recycling information.
- Do not overload wall outlets, extension cords, or adapters beyond their capacity, since this can result in fire or electric shock.
- Power-supply cords should be placed so that they are not likely to be walked on or pinched by items placed upon or against them. Pay particular attention to cords at the plug end, at wall outlets, and at the point where they exit from the appliance.
- To protect this apparatus from a lightning storm, or when left unattended and unused for long periods of time, unplug it from the wall outlet and disconnect the antenna or cable system. This will prevent damage to the set due to lightning and power line surges.
- Before plugging in the AC power cord of the TV, make sure that the operational voltage of the TV matches the voltage of your local electrical power supply. Refer to the power specifications section of the manual or the power supply label on the product for voltage and amperage information.
- Never insert anything metallic into the open parts of this apparatus. This may cause electric shock.
- To avoid electric shock, never touch the inside of this apparatus. Only a qualified technician should open this apparatus.
- Be sure to plug in the power cord until it is firmly seated. When unplugging the power cord from a wall outlet, always pull on the power cord's plug. Never unplug it by pulling on the power cord. Do not touch the power cord with wet hands.
- If this apparatus does not operate normally - in particular, if there are any unusual sounds or smells coming from it - unplug it immediately and contact an authorised dealer or Samsung service centre.
- Be sure to pull the power plug out of the outlet if the TV is to remain unused or if you are to leave the house for an extended period of time.
 - Accumulated dust can cause an electric shock, an electric leakage, or a fire by causing the power cord to generate sparks and heat or by causing the insulation to deteriorate.
- Be sure to contact an authorised Samsung service centre for information if you intend to install your TV in a location with heavy dust, high or low temperatures, high humidity, chemical substances, or where it will operate 24 hours a day such as in an airport, a train station, etc. Failure to do so may lead to serious damage to your TV.
- Use only a properly grounded plug and wall outlet.
 - An improper ground may cause electric shock or equipment damage. (Class I Equipment only.)
- To turn off this apparatus completely, disconnect it from the wall outlet. To ensure you can unplug this apparatus quickly if necessary, make sure that the wall outlet and power plug are readily accessible.
- Store the accessories in a location safely out of the reach.
- Do not drop or strike the product. If the product is damaged, disconnect the power cord and contact a Samsung service centre.
- To clean this apparatus, unplug the power cord from the wall outlet and wipe the product with a soft, dry cloth. Do not use any chemicals such as wax, benzene, alcohol, thinners, insecticide, aerial fresheners, lubricants, or detergents. These chemicals can damage the appearance of the TV or erase the printing on the product.
- Do not expose this apparatus to dripping or splashing.
- After removing the screen protective film, never remove the Polarising film.
 - If the protective film removal label is not found, the protective film has already been removed.
- **WARNING - Do not use liquid fumigators containing chemicals, such as mosquito repellent or air freshener, around the product.**
 - If steam comes in contact with the product surface or enters the product, it may cause stains or malfunction.
- **WARNING - TO PREVENT THE SPREAD OF FIRE, KEEP CANDLES AND OTHER ITEMS WITH OPEN FLAMES AWAY FROM THIS PRODUCT AT ALL TIMES.**
- Use care when touching the TV after it has been on for some time. Some parts can be warm to the touch.



Contents

Before Reading This User guide	2		
Warning! Important Safety Instructions	2		
01 What's in the Box?			
Providing proper ventilation for your TV	5		
Securing the TV to the Wall	5		
Installing the LED TV Stand	6		
Installing the wall mount kit	9		
Wall Mount Kit Specifications (VESA)	9		
02 Remote Control			
About the Buttons on the Remote Control	10		
03 Initial Setup			
Using the TV Controller	11		
04 The Connection Panel			
05 Connections			
Read Before Using the Internet Function	12		
Connecting to your Internet network	13		
Connecting the TV to a SBB or STB	14		
Connecting the Headphone Box	14		
Connecting the Bathroom Speakers	15		
06 Using a TV Viewing Card ("CI or CI+ Card")			
Connecting the "CI or CI+ Card" via COMMON INTERFACE slot with the CI CARD Adapter	15		
Using the "CI or CI+ Card"	16		
07 Setting the Hotel Option menu			
Hotel Option menu items	17		
USB Cloning	22		
Settings Cloned in the Hotel Option Menu	23		
Setting Auto Initialize	24		
Updating the TV's Software	27		
08 Editing Channels			
Using Channel Editor	27		
09 Specifications and Other Information			
Specifications	29		
Environmental Considerations	30		
Decreasing power consumption	30		
Supported Resolutions for Connecting a Computer	31		
Supported Resolutions for Video Signals	32		
Supported Resolutions for UHD Input Signals	32		
Dimensions	33		
Licences	34		

01 What's in the Box?

Make sure the following items are included with your TV. If any items are missing, contact your dealer.

- ❶ Simple User Guide
- ❷ *Warranty Card / Regulatory Guide / WEEE
- ❸ *Remote Control
- ❹ *Batteries
- ❺ *Power Cord
- ❻ *Data Cable
- ❼ *CI Card Adapter

- *: Some of the items specified above may not be included in the package, depending on the model or geographical area.
- Contact the vendor where you purchased the product if any components are missing.
- The items' colours and shapes may vary depending on the models.
- Cables not included can be purchased separately.
- Check for any accessories hidden behind or in the packing materials when opening the box.

An administration fee may be charged in the following situations:

(a) An engineer is called out at your request, but it is found that the product has no defect (i.e., where the user manual has not been read).

(b) You bring the unit to a repair centre, but it is found that the product has no defect (i.e., where the user manual has not been read).

You will be informed of the administration fee amount before a technician visits.



The screen can be damaged from direct pressure when handled incorrectly. As shown in the figure, make sure to grip the edges of the screen when you lift the TV.

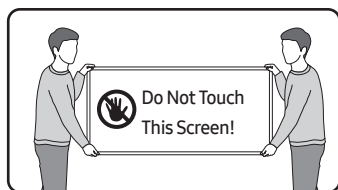

Providing proper ventilation for your TV

When you install your TV, maintain a distance of at least 10 cm between the TV and other objects (walls, cabinet sides, etc.) to ensure proper ventilation. Failing to maintain proper ventilation may result in a fire or a problem with the product caused by an increase in its internal temperature.

- When you install your TV with a stand or a wall mount, we strongly recommend you use parts provided by Samsung only. Using parts provided by another manufacturer may cause difficulties with the product or result in injury caused by the product falling.

Securing the TV to the Wall



Caution: Pulling, pushing, or climbing on the TV may cause the TV to fall. In particular, do not hang on or destabilise the TV. This action may cause the TV to tip over, causing serious injuries or death. Follow all safety precautions provided in the Safety Flyer included with your TV. For added stability and safety, you can purchase and install the anti-fall device.

Preventing the TV from falling

1. Using the appropriate screws, firmly fasten a set of brackets to the wall. Confirm that the screws are firmly attached to the wall.
 - You may need additional material such as wall anchors depending on the type of wall.
2. Using the appropriately sized screws, firmly fasten a set of brackets to the TV.
 - For the screw specifications, refer to the standard screw part in the table under "Wall Mount Kit Specifications (VESA)".
3. Connect the brackets fixed to the TV and the brackets fixed to the wall with a durable, heavy-duty string, and then tie the string tightly.
 - Install the TV near the wall so that it does not fall backwards.
 - Connect the string so that the brackets fixed to the wall are at the same height as or lower than the brackets fixed to the TV.

* This image depicts the bracket installation.

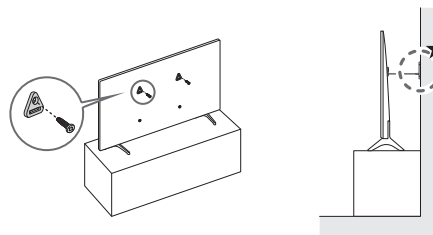

★ : Wall-anchor (not supplied)

- The product colour and shape may vary depending on the model.

Installing the LED TV Stand

Assembling the Stand and Components

When installing the stand, use the provided components and parts.



Stand
(HG**U700F* models only)

Stand
(HG**U800F* models only)

Power Cord

* This image depicts the stand assembly procedure.

[HG**U700F* models only]

1

43-65"

75"

2

43-65"

3

75"

L

R

4

5

English - 6

1

43-50"

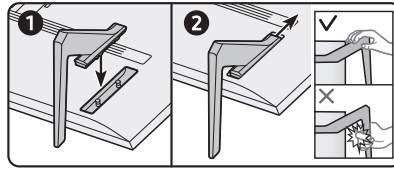
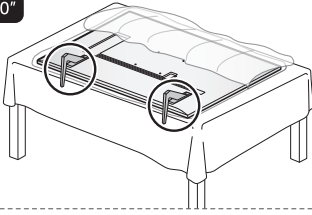

55-65"

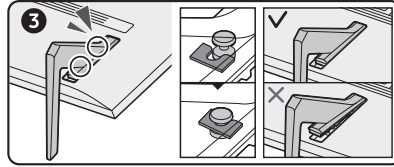
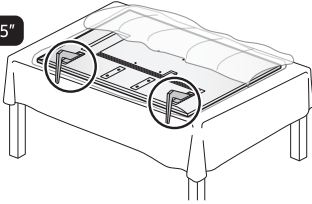

75-85"

L

R

A

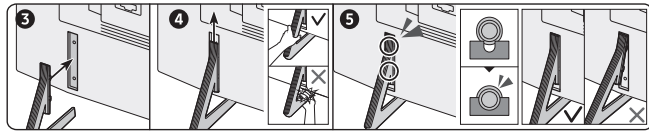
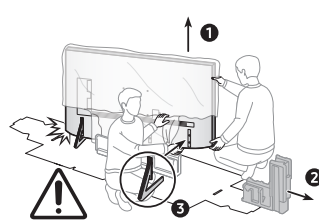
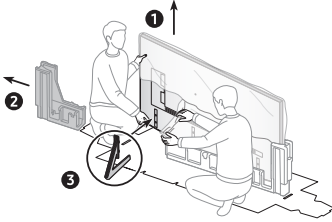

B

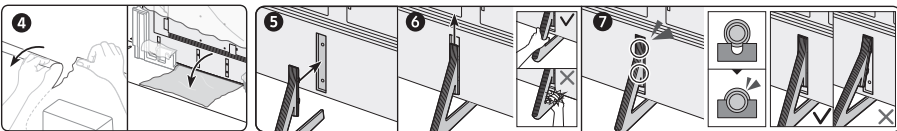
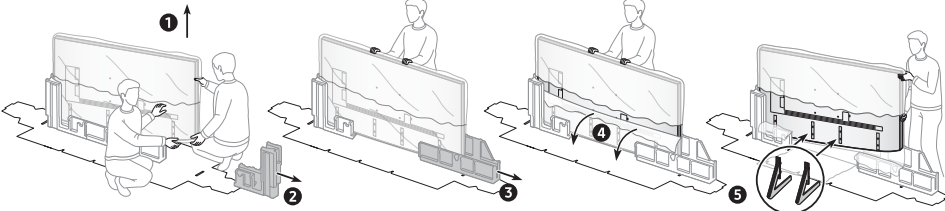

55-85"

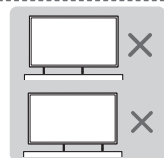
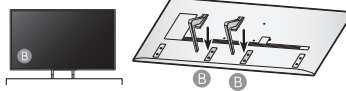
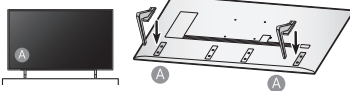

2

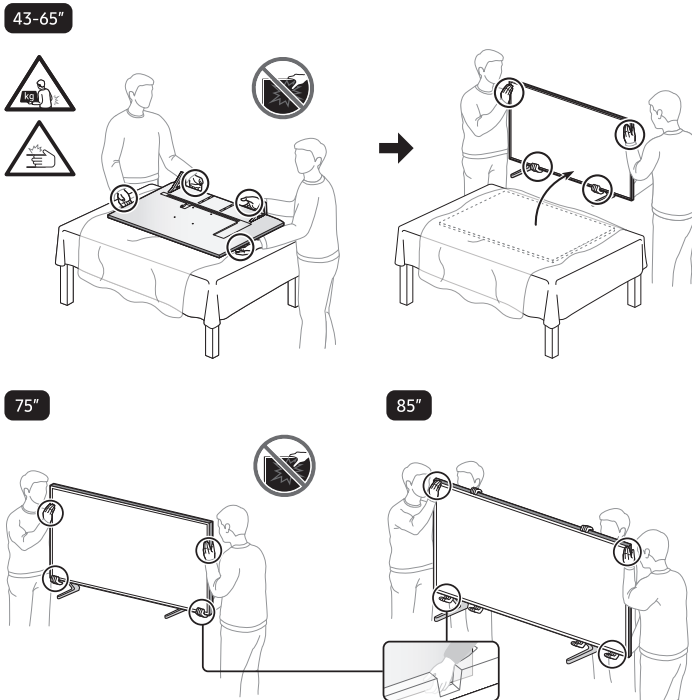

3

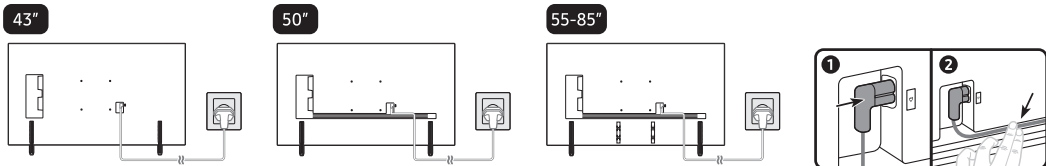

4

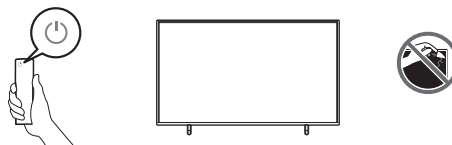

NOTE

- ★ : May not be available depending on the model and region.
- The colour and shape of parts may differ from what is shown. Specifications are subject to change without notice to improve quality.
- Make sure to distinguish between the front and back of each component when assembling them.
- Make sure that at least two persons lift and move the TV.
 - For 82 inch or larger models, have four people mount the TV onto a wall.

Installing the wall mount kit

You can mount the TV on the wall using a wall mount kit (sold separately).

* This image depicts the wall mount kit installation.

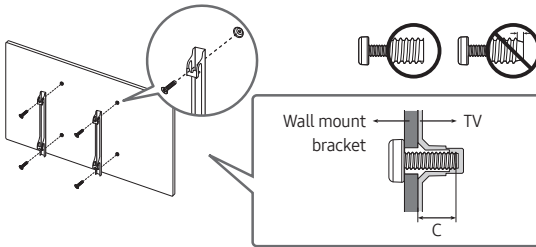

The wall mount kit (sold separately) allows you to mount the TV on a wall.

For detailed information on installing the wall mount, see the instructions provided with the wall mount. Contact a technician for assistance when installing the wall mount bracket. Samsung is not responsible for any damage to the product or injury to yourself or others if you select to install the TV on your own.

Wall Mount Kit Specifications (VESA)

Install your wall mount on a solid wall perpendicular to the floor. If you are attaching the wall mount to building materials other than plaster board, contact your nearest dealer. If installed on a ceiling or slanted wall, the TV may fall and cause severe personal injury.

- The wall mount kit is not supplied, but sold separately.
- **NOTE**
 - Standard dimensions for wall mount kits are shown in the table below.
 - Samsung wall mount kits contain a detailed installation manual. All parts necessary for assembly are provided.
 - Do not use screws that do not comply with the VESA standard screw specifications.
 - Do not use screws that are longer than the standard dimension or do not comply with the VESA standard screw specifications. Screws that are too long may cause damage to the inside of the TV set.
 - For wall mounts that do not comply with the VESA standard screw specifications, the length of the screws may differ depending on the wall mount specifications.
 - Do not fasten the screws too firmly. This may damage the product or cause the product to fall, leading to personal injury. Samsung is not liable for these kinds of accidents.
 - Samsung is not liable for product damage or personal injury when a non-VESA or non-specified wall mount is used or the consumer fails to follow the product installation instructions.
 - Do not mount the TV at more than a 15 degree tilt.
 - Always have two people mount the TV onto a wall.
 - For 82 inch or larger models, have four people mount the TV onto a wall.

* This image indicates the VESA mounting location on the rear panel.

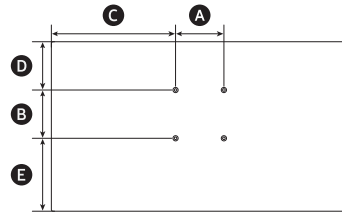

[HG**U700F* models only]

TV size in inches	VESA screw hole specs (A * B) in millimetres	C (mm)	D (mm)	E (mm)
43	200 x 200	378.9	145.5	213.2
50		455.4	210.5	233.3
55		512.3	274.2	233.5
65		622.0	398.0	233.2
75		400 x 300	634.1	448.1
TV size in inches	C (mm)	Standard Screw	Quantity	
43	23-25	M8	4	
50				
55				
65				
75	10-12			

[HG**U800F* models only]

TV size in inches	VESA screw hole specs (A * B) in millimetres	C (mm)	D (mm)	E (mm)
43	200 x 200	382.8	187.7	171.7
50		459.2	207.4	236.7
55		516.1	265.8	243.0
65	400 x 300	525.5	264.1	267.7
75	400 x 400	638.4	259.6	300.7
85	600 x 400	650.5	355.9	330.2
TV size in inches	C (mm)	Standard Screw	Quantity	
43	11-13	M8	4	
50				
55				
65				
75				
85				



Do not install your wall mount kit while your TV is turned on. This may result in personal injury from electric shock.

02 Remote Control

About the Buttons on the Remote Control

- The images, buttons, and functions of the remote control may differ with the model or geographical area.
- If you use the remote control that comes with your TV to control another TV, some functions may not operate normally.
- A button without a description in the image below is not supported on the product.
- This remote control may not be supplied, depending on the region.

* This image shows the remote control design.

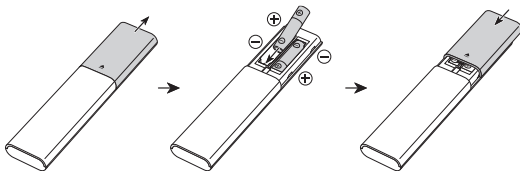
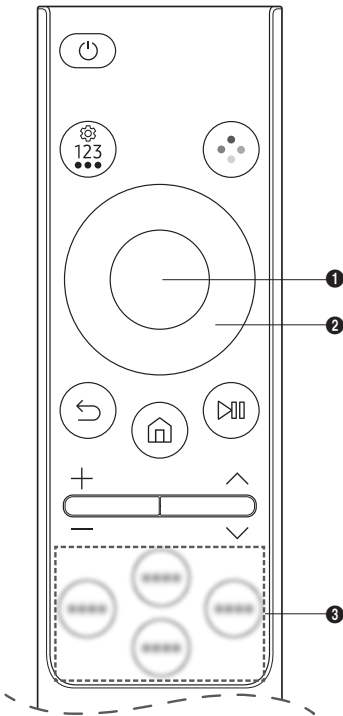







- Alkaline batteries are recommended for longer battery life.



Fire or explosion may occur, resulting in damage to the remote control or personal injury.

- Do not apply shock to the remote control.
- Be careful not to let foreign substances such as metal, liquid, or dust come in contact with the charging terminal of the remote control.
- When the remote control is damaged or you smell smoke or burning fumes, immediately stop operation and then repair it at the Samsung service centre.
- Do not arbitrarily disassemble the remote control.
- Be careful not to let infants or pets suck or bite the remote control. Fire or explosion may occur, resulting in damage to the remote control or personal injury.

 (Power)	Press to turn the TV on or off.
 (Settings - Number - Option button)	<p>You can access Colour pad / Number pad / Connected Devices / Settings / SmartThings app directly.</p> <ul style="list-style-type: none"> • Accessing the SmartThings app using this button may not be supported, depending on the model. • Use this button to access additional options that are specific to the feature in use. • Press to bring up the virtual numeric pad on the screen. Use the numeric keypad to enter numeric values. Select numbers and then select Done or Enter Number to enter a numeric value. Use to change the channel, enter a PIN, ZIP code and etc.
 (Colour button)	When pressed, coloured buttons appear on the screen. Use this button to access additional options that are specific to the feature in use.
1 Select	Selects or runs a focused item. When pressed while you are watching a broadcast programme, detailed programme information appears.
2 Directional button (up/down/left/right)	Moves the focus and changes the values seen on the TV's menu.
+ / - (Volume)	Move the button up or down to adjust the volume. To mute the sound, press the button. When pressed for 2 seconds or more, the Accessibility Shortcuts appears.
^ / v (Channel)	Move the button up or down to change the channel. To see the Guide screen, press the button. When pressed for 1 second or more, the Channel List screen appears. Press and hold the button up or down to quickly change the channel.
 (Return)	Returns to the previous menu. When pressed for 1 second or more, the running function is terminated. When pressed while you are watching a programme, the previous channel appears.
 (Play/pause)	When pressed, the playback controls appear. Using these controls, you can control the media content that is playing.
 (Smart Hub)	Press to switch to the Home Screen.
3 Launch app button	<p>Launch the app indicated by the button.</p> <ul style="list-style-type: none"> • Available apps may differ depending on the geographical area or contents provider.

03 Initial Setup

When you turn on your TV for the first time, it immediately starts the Initial Setup. Follow the instructions displayed on the screen and configure the TV's basic settings to suit your viewing environment. If you already completed the Initial Setup, run the Initial Setup again using the following menu.

- Hotel Option menu > System > TV Reset

If you select TV Reset, the TV resets all values to their factory defaults. When the TV turns off, press the Power button on the remote control to turn on the TV. The TV starts the Initial Setup.

- The Initial Setup steps may differ with the model or geographical area.

Select the region settings

- Before select region, refer to the country list information on the right.
- If you select the incorrect region, execute TV Reset again after the Initial Setup is completed.
- If the region is changed, the TV automatically turns off and on.

Selecting your TV installation type

- **Basic TV Setup:** Select to proceed to the next step to set the basic options for using your TV.
- **Cloning Mode:** Copy the system settings from the USB or server to the TV.
- **Zero Touch Configuration:** Before starting Zero Touch Configuration, connect to the network and agree to the Terms & Conditions.
- **Factory Menu:** End Initial Setup and go to Hotel Option menu directly.

- Follow the instructions on the screen to configure the settings for your own viewing environment.

Using the TV Controller

You can turn on the TV with the TV Controller button at the bottom of the TV, and then use the Control menu. The Control menu appears when the TV Controller button is pressed while the TV is On. For more information about its usage, refer to the figure below.

- The screen may dim if the protective film on the Samsung logo or the bottom of the TV is not detached. Please remove the protective film.

* This image indicates the TV and button locations.

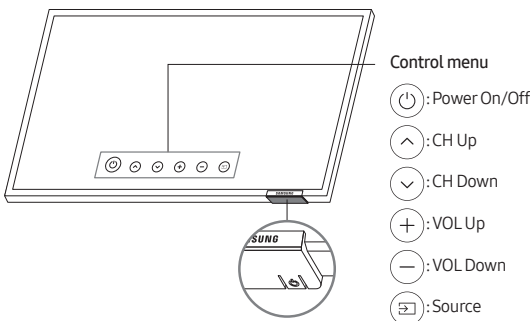

TV Controller button / Remote control sensor

Short Press: Move

Long Press & Hold: Select

The TV Controller button is located on the bottom of the TV.

04 The Connection Panel

* This image indicates the location of the connection ports on the TV.

[HG**U700F* models only]

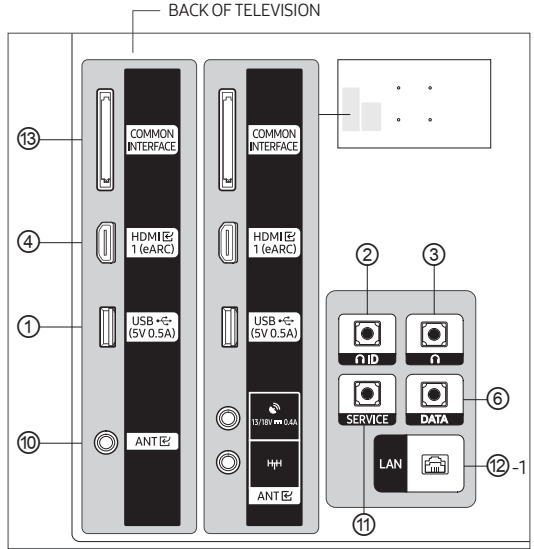

[HG**U800F* models only]

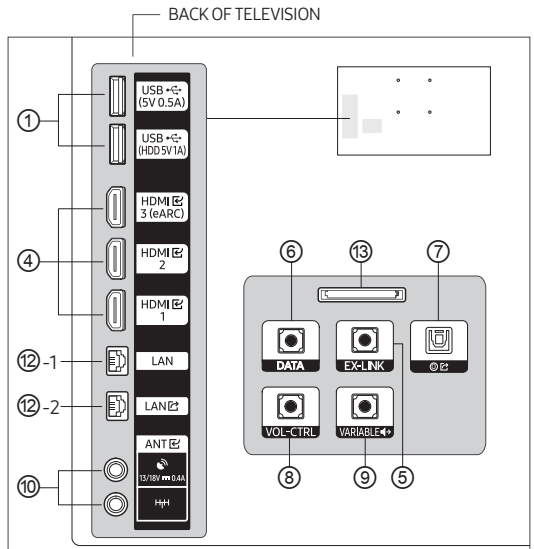

- When connecting an external device, match the colour of the connection port to the cable.
- Whenever you connect an external device to your TV, make sure that power on the TV and the device is turned off.

① USB (5V 0.5A), USB (HDD 5V1A)

- Connector for software upgrades and Media Play, etc.
- Service connection.

② HP-ID

Connect the cable to HP-ID and Headphone Jack simultaneously and connect it to separated Headphone Box. See page 14. When connecting Headphone to Headphone Box, it works same as Headphone function.

③ HEADPHONE JACK

Headphones may be connected to the headphone jack on your TV. While the headphones are connected, the sound from the built-in speakers is disabled.

④ HDMI IN 1, 2, 3(eARC)

Connects to the HDMI jack of a device with an HDMI output.

- No separate sound connection is needed for an HDMI to HDMI connection. HDMI connections carry both audio and video.
- It is recommended that the external device of the HDMI 1.3 or 1.4 version will be used with this TV. If you meet the compatible problem like no sound or the abnormal screen or etc with the device of the HDMI 1.2 version, contact to the Samsung customer care centre.

⑤ EX-LINK

Dedicated to service technicians.

⑥ DATA

- Used to support data communication between the TV and the SBB or STB.
- Connects using RJ-12 TV type plugs.

⑦ (DIGITAL AUDIO OUT)

Connects to a Digital Audio component.

⑧ VOL-CTRL

Used to control the volume of the Bathroom speaker. Connect the Volume Control Box on the Bathroom Wall and the VOL-CTRL port.

⑨ (VARIABLE AUDIO OUT)

Used for the audio output to the Bathroom speaker. Connect the Volume Control Box on the Bathroom Wall and the VARIABLE AUDIO OUT port.

⑩ (SATELLITE), (Air/CABLE)

To view television channels correctly, the TV must receive a signal from one of the following sources:

- An outdoor antenna / A cable television system / A satellite receiver

⑪ SERVICE

Service Only.

⑫-1 LAN (LAN IN)

⑫-2 LAN (LAN OUT)

To connect a LAN cable, use a CAT 7 (*STP type) cable for the connection. (100/10 Mbps)

* Shielded Twisted Pair

⑬ COMMON INTERFACE

Watches paid channels by inserting your TV viewing card ("CI or CI+ Card") into the COMMON INTERFACE slot.

05 Connections

Read Before Using the Internet Function

Read this information before using the Internet function.

- File download is not supported.
- The **Internet** function may not be able to access certain websites, including websites operated by certain companies.
- The TV does not support playback of flash videos.
- E-commerce for online purchases is not supported.
- ActiveX is not supported.
- Only a limited number of fonts are supported. Certain symbols and characters may not be displayed properly.
- The response to remote commands and the resulting on-screen display may be delayed while a webpage is loading.
- Loading a webpage may be delayed or suspended completely depending on the status of the participating systems.
- Copy and paste operations are not supported.
- When composing an email or a simple message, certain functions such as the font size and colour selection may not be available.
- There is a limit to the number of bookmarks and the size of the log file that can be saved.
- The number of windows that can be opened concurrently is limited.
- Web browsing speed will differ with the network environment.
- Embedded videos in a webpage cannot be played at the same time while the PIP (picture-in-picture) function is operating.
 - This function may not be supported depending on the model or geographical area.
- Browsing history is saved from latest to oldest, with the oldest entries being overwritten first.
- Depending on the types of video/audio codecs supported, you may not be able to play certain HTML 5 video and audio files.
- Video sources from PC-optimised streaming service providers may not play properly on our proprietary **Internet** browser.

Connecting to your Internet network

You can set up your TV so that it can access the SMART TV applications through your local area network (LAN) using a wired or wireless connection.

- After you have physically connected the TV to your network, you must configure the network connection to complete the process. You can configure the connection after the Initial Setup process, through the TV's menu (**Home Option menu > Smart Service > Network Setup > (Network Settings > Wireless or Wired)**).
- When the network is connected, it enables casting YouTube content, DLNA, Screen Mirroring, Log Downloader, SmartThings and HBB Companion Screen. Services supported by software updates are subject to change.
- To use Wi-Fi Direct, the mobile device must support the Wi-Fi Direct function. To check whether your mobile device supports Wi-Fi Direct, refer to the mobile device's user manual.
- To ensure safe and secure use of the product, connect to the network using a securely managed router.

Establishing a wireless Internet connection

Connect the TV to the Internet using a wireless access point or modem.

* This image depicts the wireless connection setup.

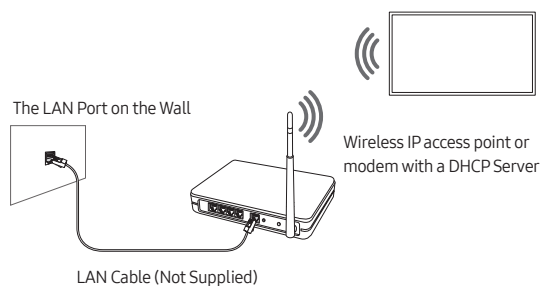

- This TV supports the IEEE 802.11 a /b /g /n /ac communication protocols. Samsung recommends using IEEE 802.11n. Otherwise, when you play video over a network connection, the video may not play smoothly.
 - Some of the IEEE 802.11 communication protocols may not be supported depending on the model or geographical area.
- To use a wireless network, the TV must be connected to a wireless access point or modem. If the wireless access point supports DHCP, the TV can use a DHCP or static IP address to connect to the wireless network.
- Select a channel that is not currently in use for the wireless access point. If the channel set for the wireless access point is currently being used by another device, the result is usually interference or a communications failure.
- Most wireless networks have an optional security system. To enable a wireless network's security system, you need to create a security key using characters and numbers, and then enter that key into the access point through its menu. You then must enter this security key into any other devices you want to connect to the wireless network.

Network Security Protocols

The TV only supports the following wireless network security protocols:

- Authentication Modes: WEP, WPA, WPA2, WPA2PSK
- Encryption Types: WEP, TKIP, AES

In compliance with the Wi-Fi certification specifications, Samsung TVs do not support WEP or TKIP security encryption in networks running in the 802.11n mode.

If the wireless access point supports WPS (Wi-Fi Protected Setup), you can connect the TV to your network using PBC (Push Button Configuration) or a PIN (Personal Identification Number). WPS automatically configures the SSID and WPA key settings.

Your Smart TV cannot connect to uncertified wireless access point.

Establishing a wired Internet connection

There are three main ways to connect the TV to your network using cable, depending on your network setup. They are illustrated below:

* This image depicts the wired network connection setup.

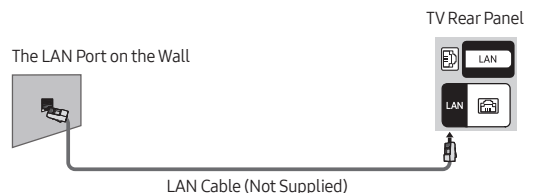
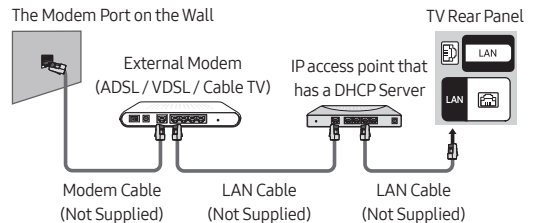
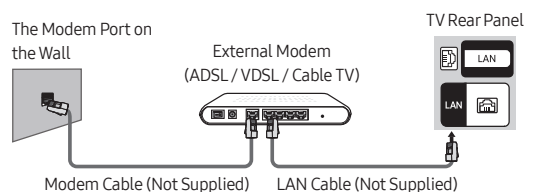

- The TV will not be able to connect to the Internet if your network speed is below 10 Mbps.
- To connect a LAN cable, use a CAT 7 (*STP type) cable for the connection. (100/10 Mbps)
 - * Shielded Twisted Pair

Connecting the TV to a SBB or STB

* This image depicts the wired network connection setup.

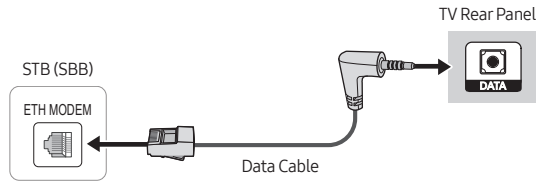

Connect the DATA port of the TV to the ETH MODEM port of the STB (SBB) with the Data cable.

- The ETH MODEM port name that you connect the Data Cable to may differ depending on the SBB or STB type.
- IR signals sent by the remote control to the TV or SBB / STB must meet the following specification to use IR pass through function.
IR signal receiver specification
 - Band pass filter centre frequency: 37.9 kHz
 - Carrier Frequency, Duty 50%
 - Minimum Burst Length (tburst): 12 pulses (316 us)
 - Minimum Gap Time Between the burst (tburst gap): 16 pulses (422 us)
 - Minimum Gap Time between the data commands (tpause): 25 ms

List of Hospitality SI Vendors and compatible data cables supplied with the TV

- Confirm you are using the correct data cable for your SI vendor. Refer to the code label on the data cables.
- Contact your nearest dealer or your SI Vendor to buy the data cable not included in the TV.

* This image depicts how to connect the data cable.

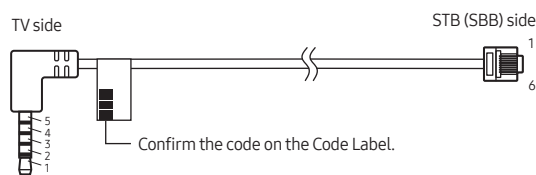

Cable code	Pin assign	Remark																												
BN39-02462A (Colour: BLACK)	<table border="1"> <tr> <th>TV SIDE</th> <th>P1</th> <th>P2</th> <th>STB (SBB) SIDE</th> </tr> <tr> <td>1: TX</td> <td>RED</td> <td>1</td> <td>1: NC</td> </tr> <tr> <td>2: RX</td> <td>GREEN</td> <td>2</td> <td>2: GND</td> </tr> <tr> <td>3: IR</td> <td>WHITE</td> <td>3</td> <td>3: TX</td> </tr> <tr> <td>4: NC</td> <td>BLACK</td> <td>4</td> <td>4: NC</td> </tr> <tr> <td>5: GND</td> <td>YELLOW</td> <td>5</td> <td>5: IR</td> </tr> <tr> <td></td> <td></td> <td>6</td> <td>6: IR</td> </tr> </table>	TV SIDE	P1	P2	STB (SBB) SIDE	1: TX	RED	1	1: NC	2: RX	GREEN	2	2: GND	3: IR	WHITE	3	3: TX	4: NC	BLACK	4	4: NC	5: GND	YELLOW	5	5: IR			6	6: IR	Samsung and others
TV SIDE	P1	P2	STB (SBB) SIDE																											
1: TX	RED	1	1: NC																											
2: RX	GREEN	2	2: GND																											
3: IR	WHITE	3	3: TX																											
4: NC	BLACK	4	4: NC																											
5: GND	YELLOW	5	5: IR																											
		6	6: IR																											

- RX and TX notation is based on TV.
- Operation Specification of Data Cable(RJ12): RS232

Connecting the Headphone Box

[HG**U700F* models only]

You can connect the Headphone box using the following method.

Audio Loop in

An additional Headphone Box can be installed on a bed or business desk for added convenience. The installation procedures are given below.

- The rear panel may differ depending on the model.
- The images below show the method for connecting the headphone box and the appearance of the headphone box.

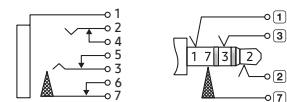
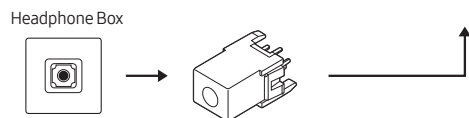
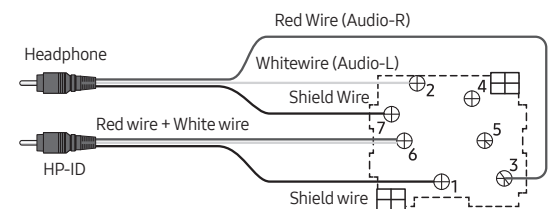
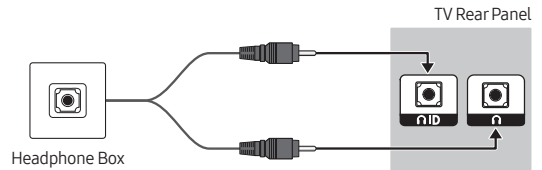

Connecting the Bathroom Speakers

[HG**U800F* models only]

You can connect the Bathroom Speakers using the following method.

Connecting through the Variable Output (available without an external amplifier)

* Please see the image below for reference. The rear panel may differ depending on the model.

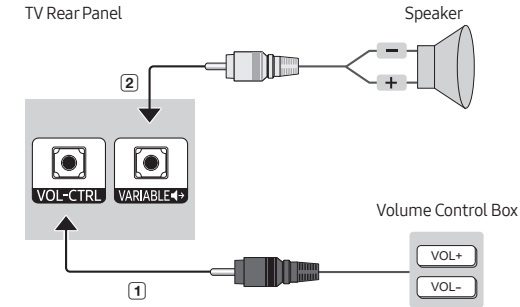

- Connect the VOL-CTRL port of the TV to the Volume Control Box Switch port on the Bathroom Wall of the hotel.
 - The maximum speaker output is 4W, 8Ω.
 - The VARIABLE AUDIO OUT port supports MONO sound out only.
- Installing the Volume Control Box
 - If you configure the Volume Control Box as shown in the figure, you can control the volume of the bathroom speakers.
 - The port that connects the Volume Control Box to the TV is a 3.5 mm normal Phone jack.
 - Volume Control Box switch is a Tact switch.
- Setting the Sub AMP Mode
 - 0: Turns the Sub AMP function off (PWM off).
 - 1: Determines the Sub volume according to the TV speaker sound volume. The TV speaker sound and VARIABLE AUDIO OUT volume are determined according to the Power On Volume Num, the Min Volume, and the Max Volume values in the Hotel Option menu.
 - 2: Determines the volume according to the Volume Control Box setting.
- VOL-CTRL Port Specifications
 - Speaker Wire: Use speaker cable no more than 25 m in length.

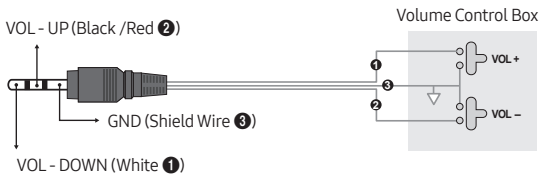

- Connect the VARIABLE AUDIO OUT port of the TV to the Bathroom Wall Speakers of the hotel.

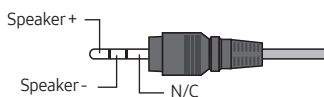

06 Using a TV Viewing Card (“CI or CI+ Card”)

Watches paid channels by inserting your TV viewing card (“CI or CI+ Card”) into the COMMON INTERFACE slot.

- The 2 CI card slots may not be supported depending on the model.
- Turn the TV off to connect or disconnect a “CI or CI+ Card”.
- The “CI or CI+ Card” may not supported depending on the model.

Connecting the “CI or CI+ Card” via COMMON INTERFACE slot with the CI CARD Adapter

Attaching the CI CARD Adapter via COMMON INTERFACE slot

To attach the CI CARD Adapter to the TV, follow these steps:

- Insert the CI CARD Adapter into the two holes on the back of TV.
 - Please locate the two holes at the back of the TV above the COMMON INTERFACE slot.
- Connect the CI CARD Adapter to the COMMON INTERFACE slot on the back of TV.

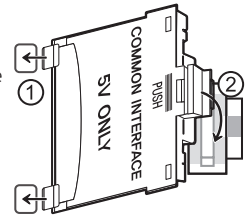

Connecting the “CI or CI+ Card”

Connect the “CI or CI+ Card” to the COMMON INTERFACE slot as shown in the image below.

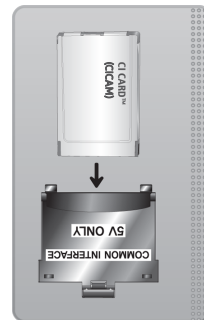

Using the “CI or CI+ Card”

To watch paid channels, the “CI or CI+ CARD” must be inserted.

- Samsung TV follow up CI+ 1.4 standard. When Samsung TV product display the pop-up message, it may happen due to CI+ 1.4 Version inconsistency. If you have a problem, please contact Samsung Call Centre.
 - Your Samsung TV conforms to the CI+ 1.4 standards.
 - Where a CI+ Common Interface module is incompatible with Samsung TV then please remove the module and contact the CI+ operator for assistance.
- If you don't insert the “CI or CI+ CARD”, some channels will display the pop-up message.
- The Pairing information will be displayed in about 2-3 minutes. If an error message is displayed, please contact your service provider.
- When the configuration of channel information has finished, the message “Updating Completed” is displayed, indicating the channel list is updated.
 - You must obtain a “CI or CI+ CARD” from a local cable service provider.
 - When removing the “CI or CI+ CARD”, carefully pull it out with your hands since dropping the “CI or CI+ CARD” may cause damage to it.
 - Insert the “CI or CI+ CARD” in the direction marked on the card.
 - The location of the COMMON INTERFACE slot may be different depending on the model.
 - “CI or CI+ CARD” are not supported in some countries and regions. check with an authorised dealer to find out if “CI or CI+ CARD” are supported in your locality.
 - If you have any problems, please contact a service provider.
 - Insert the “CI or CI+ CARD” that supports the current aerial settings. If not, the screen may not look normal.

07 Setting the Hotel Option menu

To access the **Hotel Option** menu, press the following buttons on the remote control:

1. Press the **+**/**—** button.
2. Press the up directional button.
3. Press the down directional button.
4. Press the **Select** button.

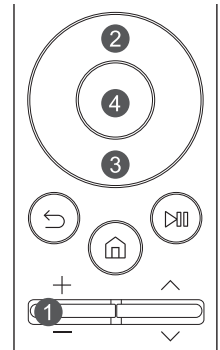

To control the TV functions in the **Hotel Option** menu, the TV has the **Standalone** mode.

- **SI Vendor: OFF / Movielink / Swisscom / SSCP**

After a menu appears, follow these general directions to navigate and change values:

- Use the directional buttons on the remote control to move from menu item to menu item.
- Press the **Select** button on the remote control to select a menu item. The screen displays that menu item only.
- Press the left or right directional button to change a value. The right directional button increases numerical values. The left arrow button decreases numerical values.
- When the screen is displaying one menu item, you can press the up or down directional button to display the next or previous menu item.
- Press the **↶** button to exit the current menu item and go to a higher menu level.
- To exit a **Hotel Option** menu, turn off the TV, and then turn it on again. Any changes you made are saved except changes to SI (System Integration) vendor. For changes to SI vendor, you must turn the TV off, wait until the power indicator at the bottom of the TV glows steadily. And then unplug the TV's power cord, wait for the power indicator to go off, and then plug the TV's power cord in again.

Hotel Option menu items

To exit from this menu, turn off (or turn off and unplug the power cable if you have changed SI vendor) the TV, and then turn on again. Any changes you made are saved.

- These functions may not be supported depending on the model or geographical area.

*: The menu items may not be supported depending on the model or geographical area.

Hotel Option menu Item	Description
Hospitality Mode	
Select Hospitality Mode .	
<ul style="list-style-type: none"> • Interactive: TV works with an SI STB or SBB. • Standalone: TV works alone, without an SI STB or SBB. 	
SI Vendor	
<ul style="list-style-type: none"> • Interactive: Samsung / 2M / Locatel / VDA / VDA-S / Acentic / Sustinere / Quadriga / ETV / IBahn / Magilink / Otrum / Siemens / Amino / MDC / Enseio • Standalone: OFF / Movielink / Swisscom / SSCP 	
SI Config	
MDC ID Settings	This function is only available when set to Hospitality Mode: Interactive, SI Vender: MDC.
Power On	
Power On Channel	Set the channel to display when the TV is turned on. <ul style="list-style-type: none"> • User Defined: Lets you set the channel number manually on Power On Channel Num. See Power On Channel Num below. • Last Saved: If you select this item, when the TV is turned on, it displays the channel it was displaying when it was turned off.
Power On Channel Num	When the TV is turned on, it switches automatically to this channel.
Power On Channel Type	Select the type of the channel will be displayed when the TV is turned on. ATV (analog air band), DTV (digital air band), CATV (analog cable band), CDTV (digital cable band), SDTV (For Satellite Models), IPTV (IP channel, IPTV is set when deployed from solution.)
Power On Volume	Set volume level when the TV is turned on. <ul style="list-style-type: none"> • User Defined: Lets you set volume level manually. • Last Saved: When the TV is turned on, it returns to the volume that had been set when the power had been turned off.
Power On Volume Num	The TV turns on with set volume level in Standalone mode .
Min Volume	The minimum volume level the user can set in Standalone mode .

Hotel Option menu Item	Description
Max Volume	The maximum volume level the user can set in Standalone mode .
Power On Source	Select the input source to be displayed when the TV is turned on.
Power On Option	Determines the TV's state when power returns after a power failure or after you have unplugged the TV and then plugged it in again. <ul style="list-style-type: none"> • Power ON: When the power returns, the TV turns on. • Standby: When the power returns, the TV enters the standby mode. • Last Option: Returns to its last power state. If it was in standby mode, it returns to standby mode. If it was on, it turns on.
Channel	
Channel Setup	Gives you direct, immediate access to some of the channel menu functions on the Broadcasting menu such as Audio Options, Auto Store etc.
Channel Editor	Lets you edit the channels stored in the TV's memory. <ul style="list-style-type: none"> • Change the channel numbers and names, manage genre and language groups and delete channels. • Apply the Screen Off to channels you select. The Screen Off blanks out the video from a channel and outputs only audio. • Lets you view information about each channel easily, without your having to display each channel directly.
Mixed Channel Map	Enables showing/browsing all antenna type (Aerial/Cable) channels at the same time. <ul style="list-style-type: none"> • ON: When set to on, guests can access the complete channel map irrespective of the selected antenna type. The Channel List/Channel Editor will also populate Aerial as well Cable type channels. • OFF: When set to off, guest can access the channel map corresponding to the selected antenna type (Aerial/Cable) only. The Channel List/Channel Editor will only show the selected antenna type channels.
Dynamic SI	<ul style="list-style-type: none"> • ON: Do not check the DTV programme channel number. • OFF: Check the DTV programme channel number.
MyChannel	ON or OFF the MyChannel function. <ul style="list-style-type: none"> • This function is available when set to Hospitality Mode: Standalone. • ON: Let hoteliers set Language and genre for the channels provided by the hotel to display the corresponding channel when user choose language and genre. • OFF: Disable MyChannel mode.

Hotel Option menu Item	Description
Channel Rescan Message	<p>When there is a mismatch between the data in the channel map and the transmitted data, the TV autotunes the channels to restore the data/parameters in the channel map.</p> <ul style="list-style-type: none"> • ON: When Channel Rescan Message is set to on, the OSD showing that the channels are being rescanned will be displayed to the guest. • OFF: When Channel Rescan Message is set to off, if the rescan message OSD should not to be displayed to the guests.
Subtitle Auto On	<p>This function turns the function on or off that automatically turns on the subtitles in a specific country.</p> <p>This function is supported for the TVs that are ready to receive DVB broadcasts that is heading to Europe.</p> <p>This function is related to France's subtitle specification. The rest of the subtitle functions available according to the country specifications regardless of Subtitle Auto On function.</p> <ul style="list-style-type: none"> • ON: When Subtitle Auto On is set to on, it follows France's subtitle specifications. • OFF: When Subtitle Auto On is set to off, it does not follow France's subtitle specifications.
TTX Widescreen Mode	<ul style="list-style-type: none"> • ON: TTX should show in 16:9 picture size. • OFF: TTX should show in 4:3 picture size.
Menu OSD	
Picture Menu Lock	ON or OFF the Picture menu.
Menu Display	<ul style="list-style-type: none"> • ON: The main menu is displayed. • OFF: The main menu is not displayed.
Channel Menu Display	<ul style="list-style-type: none"> • ON: Broadcasting menu is enable for guest. • OFF: Broadcasting menu is disable for guest.
Panel Button Lock	<p>Turning the TV Controller button operations on or off.</p> <ul style="list-style-type: none"> • Unlock: Unlocks TV Controller button. • Lock: Locks TV Controller button. • OnlyPower: Locks TV Controller button except the power off function.
Limited Menu Display	<p>This Menu is shown in following settings:</p> <ul style="list-style-type: none"> • ON: Show Menu OSD limited to condition of Interactive + SI vendor (MTI). • OFF: Default value, menu shown as per model and region.

Hotel Option menu Item	Description
Clock	
Local Time	<p>Select the way to update the clock data</p> <ul style="list-style-type: none"> • Standalone: Manual / Time Channel / TTX • Interactive: Manual / Time Channel / TTX / Auto <ul style="list-style-type: none"> – Manual: The clock is set manually by the user when the TV is in Standalone mode. – Auto: The clock is set automatically when the TV is in Interactive mode. – Time Channel: The clock is set from the selected channel. – TTX: Bring up the time information from the TTX stream.
Time Channel Type	<p>Select the type of the channel to update the clock data.</p> <p>DTV (digital air band), CDTV (digital cable band), SDTV</p> <ul style="list-style-type: none"> • This function is only available Local Time set to Time Channel.
Time Channel Num	<p>Select the number of the channel to update the clock data.</p> <ul style="list-style-type: none"> • This function is only available Local Time set to Time Channel.
NTP Settings	<p>To update TV time from server accessible over the same Network. Enable only when H.Browser Solution selected.</p> <ul style="list-style-type: none"> • Network Time Protocol: Use/Don't Use • Server URL: URL of the server from which Time is to be updated. • Time Zone: Time Zone of the region.
External Source	
USB Pop-up Screen	<p>When USB is connected to the TV :</p> <ul style="list-style-type: none"> • Automatic: This enters the USB content menu automatically. • Disable: Neither the popup window nor the menu appears.
External Source Banner	<p>If set to On, the TV displays the External Source Banner (information) when you change the TV source to another external input, press the Info key, or turn the TV on.</p> <ul style="list-style-type: none"> • ON: The External Source information is displayed on the TV screen. • OFF: The External Source information is not displayed on the TV screen.
Anynet+Return Source	Select the return TV source after stopping an Anynet+ (HDMI-CEC) connection.

Hotel Option menu Item	Description
*Headphone Management (HG**U700F* models only)	
HP Mode	<ul style="list-style-type: none"> • ON: When the Headphone is connect to the TV, allows you to listen to audio through the TV's speaker and the connected headphones simultaneously. But, you can only adjust the volumes of TV speaker. • OFF: When the Headphone is connect to the TV, allows you to listen to audio through the connected headphones only.
Default HP Volume	Configure the values of headphone's volume when HP MODE is set to ON .
Main Speaker	<ul style="list-style-type: none"> • ON: Plays the TV sound through the TV speaker. • OFF: Plays the TV sound through the headphones only.
*Bathroom Speaker (HG**U800F* models only)	
Sub Amp Mode	<p>Determines the bathroom speaker sound AMP operation mode.</p> <ul style="list-style-type: none"> • 0: Turns the bathroom speaker sound AMP function off (PWM off). • 1: The bathroom speaker sound volume follows the TV speaker sound volume identically. The bathroom speaker sound volume is controlled by the TV remote control or TV Controller button. • 2: The bathroom speaker sound volume is controlled by the bathroom speaker volume controller. • 3: TV speaker is muted. Bathroom speaker acts as main speaker and it is controlled by TV remote control or TV controller button.
Sub Amp Volume	The initial bathroom speaker sound volume after TV is turned on.
Power and Energy Saving	
Brightness Reduction	<ul style="list-style-type: none"> • ON: Turns on the energy saving function. • OFF: Turns off the energy saving function.
Cloning	
Clone TV to USB	Clone the current TV options to a USB device.
Clone USB to TV	Clone the saved TV options on a USB device to the TV.
Setting Auto Initialize	If you set Setting Auto Initialize to On , the TV menu items are restored again to their values cloned initially when the TV turns off and then on.
Zero Touch Configuration	
Before starting Zero Touch Configuration, connect to the network and agree to the Terms & Conditions.	

Hotel Option menu Item	Description
Smart Service	
Network Setup	<p>Run the Network menu to configure your TV's network settings. You can set the following items:</p> <ul style="list-style-type: none"> • Network Status: View the current network and Internet status. • Network Settings: Connect to an available network. • Hotspot: Turns on or off the Hotspot. When Hotspot is set to on, your mobile devices can find the TV name in Wi-Fi connection list. <ul style="list-style-type: none"> – When the TV connected with wireless network, Hotspot is enabled. • Reset Network: Restore the network settings to the factory default. • Expert Settings: Configure advanced network settings.
Download by App ID	Enter the App ID. Only a registered ID can be entered.
Apps Editable	<p>Provide a way to enable or disable the Apps and Notification Settings menu.</p> <ul style="list-style-type: none"> • ON: Enable the Apps and Notification Settings menu. • OFF: Disable the Apps and Notification Settings menu.
Ambient Editable	<p>Provide a way to enable or disable the Ambient Settings menu in Ambient Mode.</p> <ul style="list-style-type: none"> • ON: Enable the Ambient Settings menu. • OFF: Disable the Ambient Settings menu.
ARP interval	<p>Adjust the ARP (Address Resolution Protocol) interval value.</p> <ul style="list-style-type: none"> • Setting value: 2 / 5 / 10 / 30 / 60 / 120 / 180 second (default: 60 sec)
Terms & Policy	<p>View the entire text of the Terms & Policy document.</p> <ul style="list-style-type: none"> • You must agree to the Smart Hub service agreement.
Smart Features	<p>Run the Start Screen Options menu.</p> <ul style="list-style-type: none"> • Start with Smart Hub Home: Automatically display Smart Hub when the TV is turned on. • Autorun Multi View Mirroring : Multi View runs automatically when you mirror your mobile screen.
Quick Settings Editor	Edit the items to be displayed in Quick Settings and change their order.
Samsung Account	Create and manage your own Samsung account.

Hotel Option menu Item	Description
*LAN OUT	Enable/disable LAN Out. When enabled, the TV can work as a wired router for other network devices. – HG**U800F* models only
*VLAN ID	Create separate VLAN (Virtual Local Area Network) groups. A 3-digit number can be entered between 1 and 255 for the VLAN ID. – HG**U800F* models only
*Solution VLAN ID	When VLAN (Virtual Local Area Network) is used, set a VLAN ID to be assigned to a Solution (such as SYNC, H.Browser etc.). – HG**U800F* models only
*Device VLAN ID	Set a VLAN (Virtual Local Area Network) ID to be assigned to external devices connected to the LAN OUT port. – HG**U800F* models only
Service Discovery	Used to block or unblock UPnP (universal plug and play) protocol communications. • ON: Unblock the UPnP protocol. • OFF: Block the UPnP protocol.
IGMP version	The level in which the device is connected in the Network switch. • AUTO: Network switch is will connected automatically to available IGMP version. • V2: Network switch is will connected to IGMP version 2. • V3: Network switch is will connected to IGMP version 3.
Accessibility CC Position	• Show (Default): Show 'Position' option in Accessibility shortcut. • Hide: Hide 'Position' option in Accessibility shortcut.
SmartThing Setting	This option act as entry point to SmartThings setting GUI app.
ACM Service	Audio Control for Multi-device • ON: Sound Output shows Wifi Soundbar list. • OFF: Sound Output does not show Wifi Soundbar list
*Google Cast Settings	Google Cast is supported for Hotels having valid LYNK Cloud license. • G.Cast Enrollment Status: Inactive (Default) / Active – Active when LYNK Cloud enrollment is done with a valid license. • ToS: None (Deafult) / Accept – ToS is accepted automatically when LYNK Cloud enrollment is done with a valid license. • G.Cast Icon on Home: Hide / Show – Hotel Manager setting to control use of Google Cast feature by guest user. – HG**U800F* models only
Mobile Connection Setting	Hotel Manager setting to control use of Hotspot feature by guest user. • HotSpot icon: Hide / Show – Settings to control the use of HotSpot icons.

Hotel Option menu Item	Description
Security	
Factory Lock	Disable entry to Hotel Option menu. • ON: The password is needed before entering Hotel Option menu. • OFF: Disable this function.
Password Popup	Enable or disable password input popup window. If this option is set to off, the TV will not display the password input popup window when entering the Hotel Option menu. If set to ON , the password input popup window appears.
Password Input	If this function is enabled, the password input popup window appears which asks for an 8-character security password. The admin must enter a password before applying or updating security preferences. After the correct password is entered, options such as Password Setting , Password Reset and Security Mode are available.
Password Setting	User can change the password.
Password Reset	Password is reset to "00000000."
Security Mode	Provides password protected administrative functionality to enable or disable features of hospitality TV, such as USB , HDMI . To use this option, Security Mode set to ON . After Security Mode set to ON , options such as USB , HDMI are automatically enabled.
USB	Enable or disable USB access. If this function is set to Disable , access to USB media is blocked. Clone USB to TV and TV Reset will be disabled in the Hotel Option menu.
HDMI	Enable or disable HDMI access. If this function is set to Disable , Anynet+, HDMI source, HDMI type external channels will not be accessible to the user.
TTX Security	If this option is disabled, the TTX feature will not work when the TTX button is pressed on the remote control.
IP Control Acceptance Pop up	• ON: IP Remote Enable Pop-up is not shown. • OFF: When IP Remote option is made Disable to Enable Acceptance pop-up is shown.
DRM	
DRM Mode	Configures DRM support. • OFF: Turns off DRM support. • LYNK DRM: Select to turn on LYNK CAS support only.

Hotel Option menu Item	Description
System	
Self Diagnosis for HTV	Lets you check the state of Pro:Idiom and its communication with the SI STB or SBB. If you have any problems with the Pro:Idiom encryption channel or the communications with the SI STB or SBB, use this diagnosis function. If PI DTV Channel Key Loss (Pro:Idiom DTV Channel Key Loss) appears to have failed and the Pro:Idiom encryption channel has failed to play content, first check the broadcasting systems related to Pro:Idiom encryption. If your broadcasting system does not have a problem, contact Samsung Service. If STB SI Vendor Setting appears to have failed and communication with the SI STB or SBB has failed, first check your SI STB or SBB. If your SI STB or SBB does not have a problem, contact to Samsung Service.
Self Diagnosis for TV	<p>Run the Device Care menu.</p> <ul style="list-style-type: none"> • Power: View information on the power supply history. • Video Test: Play test videos to check for problems with the screen. • Sound Test: Play test sounds to check the sound quality. • Wi-Fi: Check whether the Wi-Fi module is working normally. The result may appear to be a failure if there is no available access point (AP) in the vicinity. • Light sensor: Check whether the light intensity sensor is working normally. • HDMI Test: Check the external device signal, signal history and HDMI cable connection, and check for an HDMI-CEC connection that is functioning abnormally. • SW Version Information: Check the currently installed software version, and update the software to the latest version, if necessary. • Picture Test: Use test photos to check for problems with the screen. • Smart Hub Connection Test: Check the network connection. • Bluetooth: Check whether the Bluetooth module is working normally. • Broadcast Signal: Check the condition of the current broadcast signal.
System Manager	<p>Gives you direct, immediate access to System Manager functions such as Time, Language, Samsung Account, Change PIN, Zero Touch Configuration.</p> <p>System Manager allow you to adjust your TV's system and customise settings for your viewing environment.</p>
OTN Update	<p>Lets you upgrade the TV Software over the network when a valid upgrade file is present on server.</p> <ul style="list-style-type: none"> • OTN Update changed to ON and disabled when Enrollment Status in LYNK Cloud is Yes.

Hotel Option menu Item	Description
SW Update	Lets you upgrade the TV Software with a USB device.
Remote Management	Allow the Samsung Call Centre to remotely access and troubleshoot your TV when you need assistance.
About This TV	Display the Samsung website, and product and software information.
Standby LED	<p>When the TV is in standby mode, you can configure the settings of the power indicator.</p> <ul style="list-style-type: none"> • ON: The LED is on. • OFF: The LED is off.
TV Reset	Returns all settings on the TV to their factory defaults.
LYNK Cloud	
Enrollment	Lets you enroll the TV with LYNK Cloud solution.
Enrollment Status	Check the status of the TV enrollment in the LYNK Cloud service.
Virtual Standby	
Virtual Standby Mode	<p>When the AC power cord is plugged in and the power is off, this option maintains the TV's important features even after the screen is off.</p> <ul style="list-style-type: none"> • Electricity consumption may vary depending on the environment.
Reboot Time	After the TV power is off (in Virtual Standby Mode) if there is no input from the user within the set Reboot Time , the TV will reboot and enter Virtual Standby Mode again.
Room Number	
You can set the room number of the TV's location.	
TEP Custom App	
TEP Custom App(URL)	<ul style="list-style-type: none"> • ON: Enables TEP custom app sub-option • OFF: Disable TEP custom app options
App Management	<p>Manages setting for TEP apps.</p> <ul style="list-style-type: none"> • Server URL: Provide URL value for TEP server. • Install: Install TEP app. • Uninstall: Remove TEP app • Timeout Setting: Default value of 30sec, Min: 30 sec, Max: 300 sec. • Use Home Key: <ul style="list-style-type: none"> – On: TEP Custom app when home key is pressed – Off: Home Menu when hoem key is pressed
CEC Control	<ul style="list-style-type: none"> • CEC Power On: HDMI CEC option are enabled. • CEC source Switching: CEC source switching is possible even during TEP custom app.
<ul style="list-style-type: none"> • Virtual Standby is available when Enrollment Status in LYNK Cloud is set to ON. • Refer to the manual of each solution for details about functions and settings of the solutions such as LYNK Cloud. 	

USB Cloning

Hotel Option menu > Cloning

The USB cloning function lets you download user-configured settings (Picture, Sound, Broadcasting, and Hotel Option menu) from one TV to a USB device, and then upload these settings from the USB device to other TV sets. This lets you create a standard file of settings and distribute that standard file to all the TVs in your facility.

- After cloning, certain features are applied when the TV is turned on again.

Cloning TV to USB: Copies stored menu settings from a TV to a USB device

Hotel Option menu > Cloning > Clone TV to USB

1. Insert a USB device into the USB port on the rear of the TV.
2. Go to the **Hotel Option** menu.
3. Press the up or down directional button to select **Clone TV to USB**, and press the **Select** button on the remote control.
4. The cloning message is displayed.
 - The clone folder will be labelled T-RSLFDEUC.
 - The cloned values include the values on the guest side menu (Picture, Sound, Broadcasting and so on) and the **Hotel Option** menu.

Cloning USB to TV: Copies menu settings and channel data in a USB device to a TV

Shortcuts: Turn the TV off, insert the USB device, turn the TV on, and then press the **Select** button on the remote control for 5 seconds.

To clone data to the TV using the **Hotel Option** menu, follow these steps:

1. Turn the TV off.
2. Insert the USB device into the USB port on the rear of the TV.
3. Turn the TV on.
4. Go to the **Hotel Option** menu.
5. Press the up or down directional button to select **Clone USB to TV**, and press the **Select** button on the remote control.
6. The message **Clone settings from USB to TV** is displayed. Press the **Select** button on the remote control.
 - If there is no file to copy on the USB device or the message that there is no file appears, check the folder on your USB device.
 - The folder name should be T-RSLFDEUC.
 - Tables that list the settings that are cloned in the **Hotel Option** menu begin on the next page.

-  Turn the TV off, insert the USB device, turn the TV on, and press the **Select** button on the remote control for 5 seconds, then this menu is displayed.

Pre-condition for cloning (check point)

- Cloning should be done between same model (same SW version).
- Before cloning, all displays should be updated at the latest version (same SW version).

Settings Cloned in the Hotel Option Menu

*: The menu items may not be supported depending on the models.

Menu Item	Sub Item	Cloned or not
Hospitality Mode	Standalone / Interactive (Default : Standalone)	Yes
SI Vendor	Interactive: Samsung / ZM / Locatel / VDA / VDA-S / Acentic / Sustinere / Quadriga / ETV / Ibahn / Magilink / Otrum / Siemens / Amino / MDC / Enseio Standalone: Off / Movielink / Swisscom / SSCP	Yes
SI Config		
MDC ID Settings	—	Yes
Power On		
Power On Channel	User Defined / Last Saved	Yes
Power On Channel Num	***	Yes
Power On Channel Type	ATV / DTV / CATV / CDTV / SDTV / IPTV	Yes
Power On Volume	User Defined / Last Saved	Yes
Power On Volume Num	0~100	Yes
Min Volume	0~100	Yes
Max Volume	0~100	Yes
Power On Source	TV / HDMI1 / *HDMI 2 / *HDMI 3 / Last Saved	Yes
Power On Option	Power On / Standby / Last Option	Yes
Channel		
Channel Setup	—	Yes
Channel Editor	—	Yes
Mixed Channel Map	On / Off	Yes
Dynamic SI	On / Off	Yes
Channel Rescan Message	On / Off	Yes
MyChannel	On / Off	Yes
Subtitle Auto On	On / Off	Yes
TTX Widescreen Mode	On / Off	Yes
Menu OSD		
Picture Menu Lock	On / Off	Yes
Menu Display	On / Off	Yes
Channel Menu Display	On / Off	Yes
Panel Button Lock	Unlock / Lock / OnlyPower	Yes
Limited Menu Display	On / Off	Yes
Clock		
Local Time	Standalone Mode: Manual / Time Channel / TTX Interactive Mode: Manual / Time Channel / TTX / Auto	Yes

Menu Item	Sub Item	Cloned or not
Time Channel Type	DTV	Yes
Time Channel Num	***	Yes
NTP Settings	—	Yes
External Source		
USB Pop-up Screen	Automatic / Disable	Yes
External Source Banner	On / Off	Yes
Anynet+Return Source	Power On Src / Last Source / TV / HDMI1 / *HDMI 2 / *HDMI 3	Yes
*Headphone Management (HG**U700F* models only)		
HP Mode	On / Off	No
Default HP Volume	0~100	No
Main Speaker	On / Off	No
*Bathroom Speaker (HG**U800F* models only)		
SubAmp Mode	0~3	No
SubAmp Volume	0~32	No
Power and Energy Saving		
Brightness Reduction	On / Off	Yes
Cloning		
Clone TV to USB	—	No
Clone USB to TV	—	No
Setting Auto initialize	On / Off	Yes
Zero Touch Configuration		
Zero Touch Configuration	—	No
Smart Service		
Network Setup	—	No
Download by App ID	—	Yes
Apps Editable	On / Off	Yes
Ambient Editable	On / Off	Yes
ARP Interval	2/5/10/30/60/120/180 sec	Yes
Terms & Policy	—	Yes
Smart Features	—	Yes
Quick Settings Editor	—	Yes
Samsung Account	—	No
*LAN OUT (HG**U800F* models only)	On / Off	Yes
*VLAN ID (HG**U800F* models only)	—	Yes
*Solution VLAN ID (HG**U800F* models only)	—	Yes
*Device VLAN ID (HG**U800F* models only)	—	Yes
Service Discovery	On / Off	Yes
IGMP VERSION	Auto / V2 / V3	Yes
Accessibility CC Position	SHOW / HIDE	Yes
SmartThings Setting	—	No
ACM Service	On / Off	Yes

Menu Item	Sub Item	Cloned or not	
*Google Cast Settings (HG**U800F* models only)	G.Cast Enrollment Status / ToS / G.Cast Icon on Home	Yes	
Mobile Connection Setting	HotSpot icon	Yes	
Security			
FactoryLock	On / Off	Yes	
Password Popup	On / Off	Yes	
Password Input	—	No	
Password Setting	—	Yes	
Password Reset	—	No	
Security Mode	On / Off	Yes	
USB	Enable / Disable	Yes	
HDMI	Enable / Disable	Yes	
TTX Security	Enable / Disable	Yes	
IP Control Acceptance Pop up	On / Off	Yes	
DRM			
DRM Mode	Off / LYNK DRM	Yes	
System			
Self Diagnosis for HTV	STB SI Vendor Setting	"Si Name" Ok / Failure	No
Self Diagnosis for TV	—	—	No
System Manager	—	—	No
OTN Update	On / Off	—	Yes
SW Update	—	—	No
Remote Management	—	—	No
About This TV	—	—	No
Standby LED	On / Off	—	Yes
TV Reset	—	—	No
LYNK Cloud			
Enrollment	—	—	No
Enrollment Status	Yes / No	—	No
Virtual Standby			
Virtual Standby Mode	On / Off	—	No
Reboot Time	5 / 15 / 30 / 60	—	Yes
Room Number	—	—	No
TEP Custom App			
TEP Custom App (URL)	On / Off	—	Yes
App Management	Server URL	—	Yes
	Install	—	No
	Uninstall	—	No
	Timeout setting	—	Yes
	Use home Key	On / Off	—
CEC Control	CEC Power On	Yes / No	Yes
	CEC Source Switching	Yes / No	Yes

Setting Auto Initialize

 **Hotel Option** menu > **Cloning** > **Setting Auto Initialize**
When you clone settings from one TV to another, you clone both the guest side menu and hotel side menu settings: **Picture**, **Sound**, **Broadcasting**, and **Hotel Option** menu. This lets you set nearly all of the menu values on your hospitality TVs to the same, standard settings. If you allow guests access to the guest side menus, for example the **Picture** menu, they can change the settings in those menus so they are no longer standard. If you set the **Setting Auto Initialize** function to on, the TV automatically restores (initializes) any guest side menu values to the cloned, standard values when the TV is turned off and then turned on again. Note that **Setting Auto Initialize** works on cloned guest side menu values only. Settings which have not been cloned are ignored.

The table below lists the settings that are restored to their cloned values when you set the **Setting Auto Initialize** function to on.

- The menu items may not be supported depending on the models.

Menu Item		
Picture		
Picture Mode	Dynamic	
	Standard	
	Eco	
	Movie	
	FILMMAKER MODE	
Expert Settings	Brightness	
	Contrast	
	Sharpness	
	Colour	
	Tint (G/R)	
	HDR Tone Mapping	
	Contrast Enhancer	
	Shadow Detail	
	Gamma	
	BT.1886	
	Apply Picture Settings	
	Film Mode	
	Colour Space Settings	Colour Space
		Colour Gamut
		Colour
		Red
		Green
Blue		
Reset		
Colour Booster		
Colour Tone		

Menu Item		
Expert Settings	White Balance	2 Point
		R-Gain
		G-Gain
		B-Gain
		R-Offset
		G-Offset
		B-Offset
		Reset
		20 Point Settings
		20 Point Interval
	Red	
	Green	
	Blue	
	Reset	
	Picture Clarity Settings	Picture Clarity
Judder Reduction		
LED Clear Motion		
Noise Reduction		
Picture Size Settings	Picture Size	
	Auto Wide	
	4:3 Screen Size	
	Fit to screen	
	Zoom and Position	
	Reset Picture	
Sound		
Sound Output	TV Speaker	
	*Receiver (Optical) (HG**U800F* models only)	
	Bluetooth Speaker List	
	Q-Symphony Setup	
Sound Mode	Standard	
	Adaptive Sound	
	Amplify	
Q-Symphony Setup		
Expert Settings	Balance	
	Equaliser	
	HDMI-eARC Mode	
	Digital Output Audio Format	
	Digital Output Audio Delay	
	Auto Volume	
	Simultaneous Optical Output	
	Reset Sound	

Menu Item		
Connections		
Network	Network Status	
	Network Settings	
	Hotspot	
	Reset Network	
	Expert Settings	Power On with Mobile
		IP Remote
		Wi-Fi
Bluetooth		
Device Connection Manager	Access Notification	
	Device List	
*Apple AirPlay Settings (HG**U800F* models only)		
*Google Cast Settings (HG**U800F* models only)		
Advanced Features		
Game Mode Settings	Game Mode	
	Game Motion Plus Settings	Game Motion Plus
		Judder Reduction
		LED Clear Motion/ Clear motion
Start Screen Options	Start with Smart Hub Home	
	Aurorun Multi View Mirroring	

Menu Item		
General & Privacy		
Accessibility	Voice Guide Settings	Voice Guide
		Volume
		Speed
		Pitch
		TV Background Volume
	Audio Description Settings	Audio Description
		Audio Description Volume
	Auto Picture Off	
	High Contrast	
	Zoom Menu and Text	
	Greyscale	
	Colour Inversion	
	SeeColors Mode	
	Subtitle Settings	Subtitle
		Subtitle Mode
		Subtitle Language
		Primary Subtitle Language
	Sign Language Zoom Settings	Sign Language Zoom
		Edit Sign Language Zoom
	Multi-output Audio	
	Remote Button Repeat Settings	Slow Button Repeat
		Repeat Interval
	Accessibility Shortcut Settings	Accessibility Shortcuts
Audio Description On/Off		
Subtitles On/Off		
Time to Take Action	Audio Description and Subtitles On/Off	
	Moving Text and Image On/Off	
Terms & Privacy		

Menu Item	
Power and Energy Saving	Brightness Optimisation
	Minimum Brightness
	Energy Saving Solution
	Motion Lighting
	Screen Saver
	Sleep Timer
	Auto Power Saving
	Auto Power Off
Broadcasting	Aerial
	Auto Tuning
	Common Interface
	Dual Sound
Parental Settings	Expert Settings
	Programme Rating Lock
	Apply Channel Lock
External Device Manager	Channel Lock Settings
	Anynet+ (HDMI-CEC)
	Input Signal Plus
Time	HDMI Black Level
	Clock Mode
	Date
	Time
	Time Offset
	Time Zone
	GMT
DST	
Alarm	
Language	
Menu Style	
Keyboard and Mouse	Keyboard Settings
	Mouse Settings
Sound Feedback	
Change PIN	
Zero Touch Configuration	
Support	
Device Care	
Remote Management	
Software Update	Update now
About The TV	

Updating the TV's Software

DO NOT turn off the TV's power until the update is complete. The TV will turn off and on automatically after completing the software update. Video and audio settings will be reset to their defaults after a software update. To easily reset the settings after software update, we recommend you to copy the TV's settings.

- For more information about the USB cloning function, refer to page 22.

Updating through a USB device

To update the TV's software, follow these steps:

1. Insert a USB device containing the software update file into the USB port of the TV.
2. Run **SW Update**.
 - **Hotel Option menu > System > SW Update**
3. The TV displays a pop-up message that checks for the updated version.
4. Move the focus to **OK**, and then press the **Select** button on the remote control.
 - Please be careful to not disconnect the power or remove the USB device while upgrades are being applied. The TV will turn off and turn on automatically after completing the SW upgrade. Please check the SW version after the upgrades are complete.

08 Editing Channels

Using Channel Editor

 **Hotel Option menu > Channel > Channel Editor**
Using **Channel Editor** you can edit the channels stored in the TV's memory.

- Change the channel numbers and names, edit the channel language and channel genre and delete channels.
- If you set the **Screen Off** function to **On** for the selected channels, a screen off message is displayed, and pictures are turned off by the **Screen Off** function and only audio is output from those channels.
- **Channel Editor** also lets you view information about each channel easily, without your having to display each channel directly.

General Steps for Using the Channel Editor in Standalone Mode

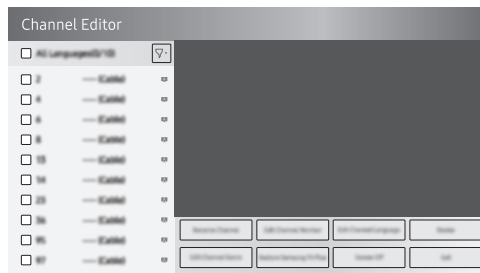

- The image on your TV may differ from the image above depending on the model and geographical area.
1. Run **Channel Setup** (**Channel > Channel Setup**) in the **Hotel Option** menu.
 2. Enter **Channel Editor** (**Channel > Channel Editor**) in the **Hotel Option** menu.
 3. On a piece of paper, compile a list of channels you want to have, arranged in the order you want.
 4. Based on the list created in Step 3, rearrange the channels and edit the channel names.
 5. Press the  button to exit.

Editing the Channel Number

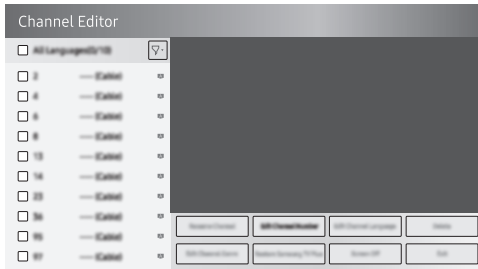

Change the channel number of a channel you select. To change a channel number, follow these steps:

1. Select a channel on the **Channel Edit** screen.
2. Use the directional buttons on the remote control, move the focus to **Edit Channel Number**, and press the **Select** button.
3. Use the up or down directional buttons on the remote control to change the channel number.
4. Move the focus to **OK** when done, and then press the **Select** button on the remote control.
 - When you change the channel number, the channel information is updated automatically.

Rename the Channel

Change the name of a channel you select. To change the name of a channel, follow these steps:

1. Select a channel on the **Channel Edit** screen.
2. Use the directional buttons on the remote control, move the focus to **Rename channel**, and then press the **Select** button.
3. Use the on-screen keyboard that appears to enter the new name for the channel. Use the directional buttons on the remote control, move the focus a letter or number, and then press the **Select** button. Repeat for each letter or number you want to enter.
4. When finished, move the focus to **Done**, and then press the **Select** button on the remote control.

Assigning the Channel Number to the external device

The external device source of the TV are displayed in the last page of the **Channel Editor** menu as shown below.

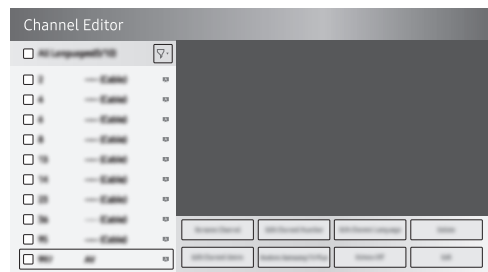
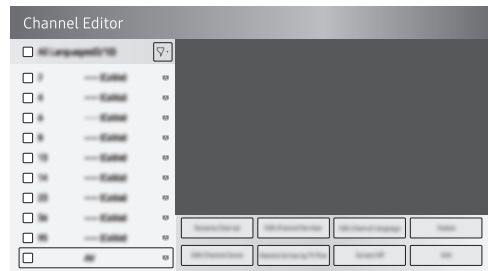

1. Select a external device source on the **Channel Edit** screen.
2. Use the directional buttons on the remote control, move the focus to **Edit Channel Number**, and press the **Select** button.
3. Use the up or down directional buttons on the remote control to assign the channel number.
4. Move the focus to **OK** when done, and then press the **Select** button on the remote control.
 - Once you assign a channel number to an external device, you can enter the external device without opening the TV source menu.

09 Specifications and Other Information

Specifications

[HG**U700F* models only]

Model Name	HG43U700F*	HG50U700F*
Display Resolution	3840 x 2160	3840 x 2160
Screen Size Measured Diagonally	43 inches 108 cm	50 inches 125 cm
Sound (Output)	20 W	20 W
Dimensions (W x H x D) Body With Stand	957.8 x 558.8 x 76.3 mm 957.8 x 609.0 x 157.0 mm	1110.8 x 643.8 x 76.4 mm 1110.8 x 695.1 x 199.0 mm
Weight Without Stand / With Stand	6.8 kg / 7.0 kg	8.7 kg / 8.9 kg
Power Consumption	115 W	125 W

Power Supply AC100-240V~ 50/60Hz

Model Name	HG55U700F*	HG65U700F*	HG75U700F*
Display Resolution	3840 x 2160	3840 x 2160	3840 x 2160
Screen Size Measured Diagonally	55 inches 138 cm	65 inches 163 cm	75 inches 189 cm
Sound (Output)	20 W	20 W	20 W
Dimensions (W x H x D) Body With Stand	1224.6 x 707.8 x 76.6 mm 1224.6 x 759.1 x 199.0 mm	1444.1 x 831.2 x 76.8 mm 1444.1 x 882.2 x 222.0 mm	1668.1 x 957.8 x 77.0 mm 1668.1 x 1005.9 x 280.0 mm
Weight Without Stand / With Stand	10.1 kg / 10.3 kg	14.7 kg / 15.0 kg	22.7 kg / 23.1 kg
Power Consumption	130 W	175 W	230 W

Power Supply AC100-240V~ 50/60Hz

[HG**U800F* models only]

Model Name	HG43U800F*	HG50U800F*	HG55U800F*
Display Resolution	3840 x 2160	3840 x 2160	3840 x 2160
Screen Size Measured Diagonally	43 inches 108 cm	50 inches 125 cm	55 inches 138 cm
Sound (Output)	20 W	20 W	20 W
Dimensions (W x H x D) Body With Stand	965.5 x 559.4 x 25.7 mm 965.5 x 614.7 x 198.4 mm	1118.3 x 644.1 x 25.7 mm 1118.3 x 701.5 x 238.6 mm	1232.1 x 708.8 x 25.7 mm 1232.1 x 768.1 x 238.6 mm
Weight Without Stand / With Stand	7.9 kg / 8.2 kg	10.8 kg / 11.2 kg	13.9 kg / 14.3 kg
Power Consumption	145 W	160 W	200 W

Power Supply AC100-240V~ 50/60Hz

Model Name	HG65U800F*	HG75U800F*	HG85U800F*
Display Resolution	3840 x 2160	3840 x 2160	3840 x 2160
Screen Size Measured Diagonally	65 inches 163 cm	75 inches 189 cm	85 inches 214 cm
Sound (Output)	20 W	20 W	20 W
Dimensions (W x H x D) Body With Stand	1450.9 x 831.8 x 25.7 mm 1450.9 x 890.0 x 270.4 mm	1676.7 x 960.3 x 26.6 mm 1676.7 x 1017.5 x 327.7 mm	1900.9 x 1086.1 x 26.9 mm 1900.9 x 1141.9 x 365.6 mm
Weight Without Stand / With Stand	20.7 kg / 21.2 kg	29.1 kg / 29.7 kg	40.4 kg / 41.3 kg
Power Consumption	250 W	320 W	350 W

Power Supply AC100-240V~ 50/60Hz

Environmental Considerations

Operating Temperature	Operating Humidity	10 °C to 40 °C (50 °F to 104 °F)	10 % to 80 %, non-condensing
Storage Temperature	Storage Humidity	-20 °C to 45 °C (-4 °F to 113 °F)	5 % to 95 %, non-condensing

Notes

- This device is a Class B digital apparatus.
- Design and specifications are subject to change without prior notice.
- For information about the power supply, and more information about power consumption, refer to the information on the label attached to the product.
 - On most models, the label is attached to the back of the TV. (On some models, the label is inside the cover terminal.)
- To connect a LAN cable, use a CAT 7 (*STP type) cable for the connection. (100/10 Mbps)
* Shielded Twisted Pair
- Recommended hours of use per day of this product is under 8 hours. If the product is used for longer than 8 hours a day, the warranty may be void.
- Download the User guide from the following Samsung Website for further details.
<http://www.samsung.com/business>

Decreasing power consumption

When you shut the TV off, it enters Standby mode. In Standby mode, it continues to draw a small amount of power. To decrease power consumption, unplug the power cord when you don't intend to use the TV for a long time.

Supported Resolutions for Connecting a Computer

When you use your TV as a computer monitor, you can also select one of the standard resolutions listed in the Resolution column. The TV will automatically adjust to the resolution you choose.

Mode	Resolution	Display format	Horizontal frequency (KHz)	Vertical frequency (Hz)	Clock frequency (MHz)	Polarity (horizontal / vertical)
IBM	720 x 400	70 Hz	31.469	70.087	28.322	-/+
MAC	640 x 480	67 Hz	35.000	66.667	30.240	-/-
	832 x 624	75 Hz	49.726	74.551	57.284	-/-
	1152 x 870	75 Hz	68.681	75.062	100.000	-/-
VESA DMT	640 x 480	60 Hz	31.469	59.940	25.175	- / -
	640 x 480	72 Hz	37.861	72.809	31.500	- / -
	640 x 480	75 Hz	37.500	75.000	31.500	- / -
	800 x 600	60 Hz	37.879	60.317	40.000	+ / +
	800 x 600	72 Hz	48.077	72.188	50.000	+ / +
	800 x 600	75 Hz	46.875	75.000	49.500	+ / +
	1024 x 768	60 Hz	48.363	60.004	65.000	- / -
	1024 x 768	70 Hz	56.476	70.069	75.000	- / -
	1024 x 768	75 Hz	60.023	75.029	78.750	+ / +
	1152 x 864	75 Hz	67.500	75.000	108.000	+ / +
	1280 x 720	60 Hz	45.000	60.000	74.250	+ / +
	1280 x 800	60 Hz	49.702	59.810	83.500	- / +
	1280 x 1024	60 Hz	63.981	60.020	108.000	+ / +
	1280 x 1024	75 Hz	79.976	75.025	135.000	+ / +
	1440 x 900	60 Hz	55.935	59.887	106.500	- / +
	1600 x 900	60 Hz	60.000	60.000	108.000	+ / +
	1680 x 1050	60 Hz	65.290	59.954	146.250	- / +
1920 x 1080	60 Hz	67.500	60.000	148.500	+ / +	
VESA CVT	2560 x 1440	60 Hz	88.787	59.951	241.500	+ / -
	2560 x 1440	120 Hz	192.996	119.998	497.750	+ / -
CTA-861	*1920 x 1080	100 Hz	112.500	100.000	297.000	+ / +
	*1920 x 1080	120 Hz	135.000	120.003	297.000	+ / +
	3840 x 2160	30 Hz	67.500	30.000	297.000	- / -
	*3840 x 2160	60 Hz	135.000	60.000	594.000	- / -

- *: The resolution may not be supported depending on the model.
- The interlaced mode is not supported.
- The set might operate abnormally if you select a non-standard video format.
- Separate and Composite modes are supported. SOG (Sync On Green) is not supported.
- Set **Apps Editable** to **ON** to change the input source (**Edit Name/Icon**) manually.
 - Hotel Option menu > Smart Service > Apps Editable

Supported Resolutions for Video Signals

Check the resolutions supported for video signals.

Mode	Resolution	Display format	Horizontal frequency (KHz)	Vertical frequency (Hz)	Clock frequency (MHz)	Polarity (horizontal / vertical)
CTA-861	720 (1440) x 576i	50 Hz	15.625	50.000	27.000	- / -
	720 (1440) x 480i	60 Hz	15.734	59.940	27.000	- / -
	720 x 576	50 Hz	31.250	50.000	27.000	- / -
	720 x 480	60 Hz	31.469	59.940	27.000	- / -
	1280 x 720	50 Hz	37.500	50.000	74.250	+ / +
	1280 x 720	60 Hz	45.000	60.000	74.250	+ / +
	1920 x 1080i	50 Hz	28.125	50.000	74.250	+ / +
	1920 x 1080i	60 Hz	33.750	60.000	74.250	+ / +
	1920 x 1080	24 Hz	27.000	24.000	74.250	+ / +
	1920 x 1080	25 Hz	28.125	25.000	74.250	+ / +
	1920 x 1080	30 Hz	33.750	30.000	74.250	+ / +
	1920 x 1080	50 Hz	56.250	50.000	148.500	+ / +
	*1920 x 1080	100 Hz	112.500	100.000	297.000	+ / +
	*1920 x 1080	120 Hz	135.000	120.003	297.000	+ / +
	1920 x 1080	60 Hz	67.500	60.000	148.500	+ / +
	3840 x 2160	24 Hz	54.000	24.000	297.000	+ / +
	3840 x 2160	25 Hz	56.250	25.000	297.000	+ / +
	3840 x 2160	30 Hz	67.500	30.000	297.000	+ / +
*3840 x 2160	50 Hz	112.500	50.000	594.000	+ / +	
*3840 x 2160	60 Hz	135.000	60.000	594.000	+ / +	
VESA CVT	2560 x 1440	60 Hz	88.787	59.951	241.500	+ / -
	2560 x 1440	120 Hz	192.996	119.998	497.750	+ / -

- *: The resolution may not be supported depending on the model.
- Set **Apps Editable** to ON to change the input source (**Edit Name/Icon**) manually.
 - Hotel Option menu > Smart Service > Apps Editable

Supported Resolutions for UHD Input Signals

- Resolution: 3840 x 2160p

If Input Signal Plus is set to Off

Frame rate (fps)	Colour Depth / Chroma Sampling	RGB 4:4:4	YCbCr 4:4:4	YCbCr 4:2:2	YCbCr 4:2:0
50 / 60	8 bit	-	-	-	0

If Input Signal Plus is set to On

Frame rate (fps)	Colour Depth / Chroma Sampling	RGB 4:4:4	YCbCr 4:4:4	YCbCr 4:2:2	YCbCr 4:2:0
50 / 60	8 bit	0	0	0	0
	10 bit	-	-	0	0

Dimensions

Front view / Side view

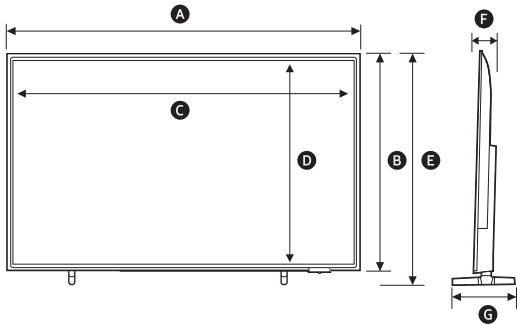

[HG**U700F* models only]

Unit: mm	43	50	55	65	75
A	957.8	1110.8	1224.6	1444.1	1668.1
B	558.8	643.8	707.8	831.2	957.8
C	955.0	1107.8	1221.6	1440.5	1664.2
D	537.3	623.4	687.4	810.5	936.3
E	609.0	695.1	759.1	882.2	1005.9
F	76.3	76.4	76.6	76.8	77.0
G	157.0	199.0	199.0	222.0	280.0

Rear view

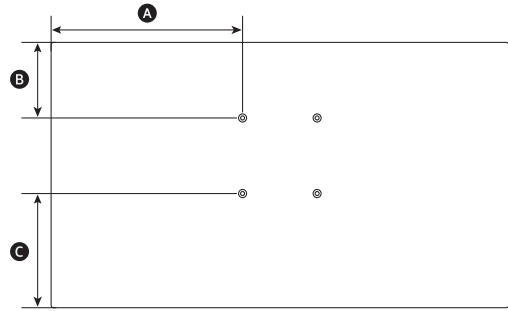

[HG**U700F* models only]

Unit: mm	43	50	55	65	75
A	378.9	455.4	512.3	622.0	634.1
B	145.5	210.5	274.2	398.0	448.1
C	213.2	233.3	233.5	232.2	210.2

[HG**U800F* models only]

Unit: mm	43	50	55	65	75	85
A	382.8	459.2	516.1	525.5	638.4	650.5
B	187.7	207.4	265.8	264.1	259.6	355.9
C	171.7	236.7	243.0	267.7	300.7	330.2

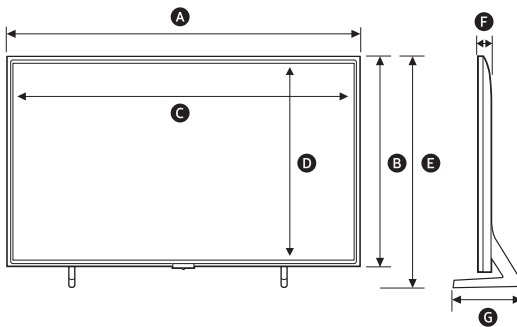

[HG**U800F* models only]

Unit: mm	43	50	55	65	75	85
A	965.5	1118.3	1232.1	1450.9	1676.7	1900.9
B	559.4	644.1	708.8	831.8	960.3	1086.1
C	953.0	1105.8	1218.2	1438.5	1662.2	1884.0
D	538.0	623.4	686.7	810.5	936.8	1061.5
E	614.7	701.5	768.1	890.0	1017.5	1141.9
F	25.7	25.7	25.7	25.7	26.6	26.9
G	198.4	238.6	238.6	270.4	327.7	365.6

Base Stand detail

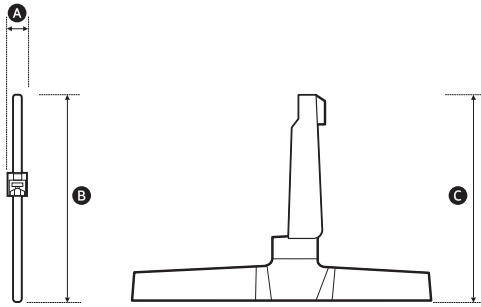

[HG**U700F* models only]

Unit: mm	43	50-55	65	75
A	25.0	25.0	25.0	25.0
B	157.0	199.0	222.0	280.0
C	161.6	167.0	173.7	183.6

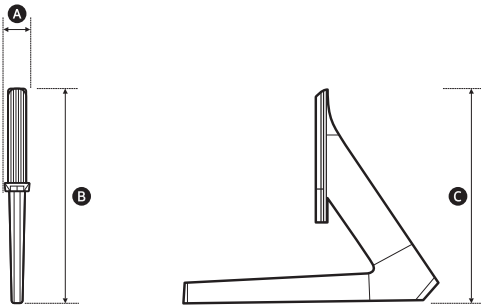

[HG**U800F* models only]

Unit: mm	43	50-55	65	75	85
A	16.0	18.0	18.2	19.3	20.0
B	198.4	238.6	270.4	327.7	365.6
C	214.9	221.5	237.0	253.8	267.3

Licences

Dolby Audio

Dolby, Dolby Atmos, Dolby Audio and the double-D symbol are registered trademarks of Dolby Laboratories Licensing Corporation. Manufactured under license from Dolby Laboratories. Confidential unpublished works. Copyright © 2012-2021 Dolby Laboratories. All rights reserved.

HEVC Advance™

Covered by Patents at patentlist.hevcadvance.com

THIS PRODUCT IS SOLD WITH A LIMITED LICENCE AND IS AUTHORISED TO BE USED ONLY IN CONNECTION WITH HEVC CONTENT THAT MEETS EACH OF THE THREE FOLLOWING QUALIFICATIONS: (1) HEVC CONTENT ONLY FOR PERSONAL USE; (2) HEVC CONTENT THAT IS NOT OFFERED FOR SALE; AND (3) HEVC CONTENT THAT IS CREATED BY THE OWNER OF THE PRODUCT.

THIS PRODUCT MAY NOT BE USED IN CONNECTION WITH HEVC ENCODED CONTENT CREATED BY A THIRD PARTY, WHICH THE USER HAS ORDERED OR PURCHASED FROM A THIRD PARTY, UNLESS THE USER IS SEPARATELY GRANTED RIGHTS TO USE THE PRODUCT WITH SUCH CONTENT BY A LICENSED SELLER OF THE CONTENT.

YOUR USE OF THIS PRODUCT IN CONNECTION WITH HEVC ENCODED CONTENT IS DEEMED ACCEPTANCE OF THE LIMITED AUTHORITY TO USE AS NOTED ABOVE.

HDMI™

HIGH-DEFINITION MULTIMEDIA INTERFACE

The terms HDMI, HDMI High-Definition Multimedia Interface, HDMI trade dress and the HDMI Logos are trademarks or registered trademarks of HDMI Licensing Administrator, Inc.

Open Source License Notice

Open Source used in this product can be found on the following webpage. (<https://opensource.samsung.com>)

SAMSUNG

Contact Samsung world wide

If you have any questions or comments relating to Samsung products, please contact the Samsung service centre.

Country/Region	Samsung Service Centre 📞	Website
RUSSIA	8-800-555-55-55	www.samsung.com/ru/support
BELARUS	810-800-500-55-500	www.samsung.com/ru/support
GEORGIA	0-800-555-555	www.samsung.com/az/support/ge
ARMENIA	0-800-05-555	www.samsung.com/ru/support
AZERBAIJAN	0-88-555-55-55	www.samsung.com/az/support
KAZAKHSTAN	8-10-800-500-55-500 (GSM: 7799)	www.samsung.com/kz_ru/support
UZBEKISTAN	00-800-500-55-500 (GSM: 7799, 0799 (Uztelecom))	www.samsung.com/uz_ru/support
KYRGYZSTAN	00-800-500-55-500 (GSM: 9977)	www.samsung.com/kz_ru/support
TAJIKISTAN	8-10-800-500-55-500 (GSM: 7779)	www.samsung.com/kz_ru/support
MONGOLIA	1800-25-55	www.samsung.com/mn/support/contact
UKRAINE	0-800-502-000	www.samsung.com/ua/support (Ukrainian)
MOLDOVA	+373-22-667-400	www.samsung.com/ua/support/moldova